

Wireless Photoelectric Smoke Detector



The wireless, low profile, photoelectric smoke detector is based on the System Sensor i3™ series platform. The detector has a green LED to indicate standby within proper sensitivity, and a red LED to indicate alarm, maintenance, and low battery. The detector features a state-of-the-art optical sensing chamber, a built-in sounder, a mechanical test switch, and the capability of monitoring for smoke 24 hours a day to allow for a quick response to a fire whether you're home or not.



Features

- Powered by 3-volt lithium battery
- Wide angle, dual color LED indication
- 85 dB sounder
- Built-in test switch
- Mounts to octagonal and single-gang back boxes, 4-square back boxes, or direct to ceiling
- Removable detector cover and chamber
- Stop-Drop 'N Lock attachment to base
- Drift Compensation™ and smoothing algorithms reduce nuisance false alarms and trouble signals
- Simplified sensitivity measurement
- Tamper-resistant feature prevents removal from the mounting base without the use of a tool
- Each transmitter has a unique factory-programmed code that distinguishes itself to the receiver
- Fast fire bypass allows detection of large fires faster



Wireless Photoelectric Smoke Detector

Specifications

Power

- Battery: 3.0V CR123A, lithium batteries
- Average Battery Life: 3-5 years

Physical Specifications

- Diameter (including base): 5.3 inches
- Height (including base): 2.0 inches
- Sensitivity: 2.5%/ft. nominal
- Sound Pressure Output: 85 dBA

Wireless

- Transmitting Frequency: 319.5 MHz and 345 MHz
- Supervision Interval: 60 minutes
- Transmit Range: Maximum of 500 feet, open air

Mounting

- 3½-inch or 4-inch octagonal back box
- Single gang back box
- 4-inch square back box with a plaster ring
- Direct mount to ceiling

Environmental

- Operating Temperature: 32°F to 100°F (0°C to 38°C)
- Storage Temperature: - 4°F to 158°F (- 20°C to 70°C)
- Max. Humidity: 90% relative humidity, non condensing

Approvals/Listings

- FCC 15
- UL (Pending)

Illustrations

Removing Screen/Sensing Chamber

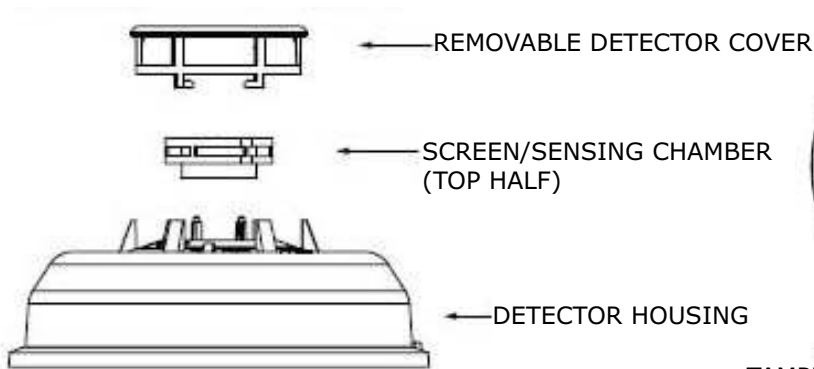

Tamper-Resistant Feature

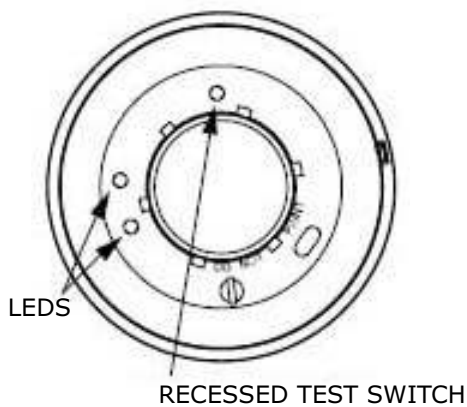
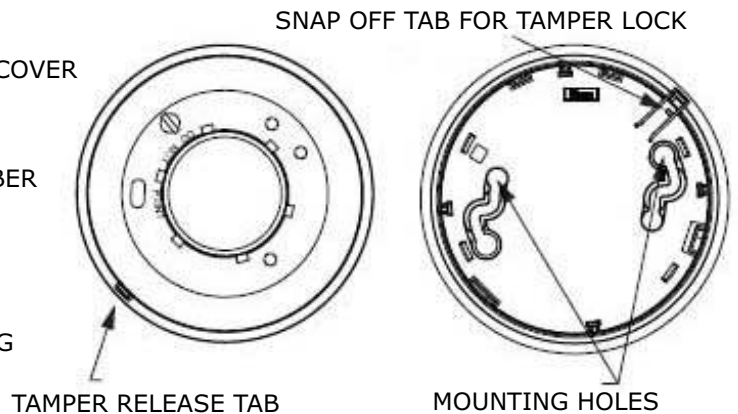

Realty Automation & Security Systems Pvt. Ltd.

5, New Sadashiv Peth,
Near Alka Talkies, Pune 411030.
Website: www.vighnaharta.in

Tel: +91 20 32922630 / 32921306
Telfax: +91 20 24339628
Email: sales@vighnaharta.in